

# **Plate System for 5.0L Coyote Engines**



## **Installation Instructions**

**Read all Instructions before beginning!!!**

**Caution – EXTREME DANGER – Caution**

**Do not use or mix any other manufacturer’s products with any Nitrous Express products.**

**Do not use or mix any Nitrous Express products with any other manufacturer’s products.**

**THESE INSTRUCTIONS APPLY TO NITROUS EXPRESS PRODUCTS ONLY!**

**FOR SANCTIONED RACE USE ONLY - NOT FOR SALE OR USE IN CALIFORNIA**

**CAUTION:** An experienced technician familiar with the use and handling of high-pressure cryogenic gases should install this system. If you have any doubt about your skills this system should be taken to a qualified shop for installation. If you have decided to do the install yourself please read and understand all of these instructions before you start. Some of these instructions may or may not apply to your vehicle, if you have any questions please call our tech department 940-767-7694 9:00A.M.-5:00P.M. CST.

Before starting, disconnect the negative terminal on the battery. If you have any questions about your particular vehicle consult a shop manual.

**These instructions are divided into 6 sections:**

1. **Mounting the Bottle**
2. **Routing the Supply Line**
3. **Mounting the Plate**
4. **Plumbing the Fuel System**
5. **Wiring**
6. **Testing the System**
7. **Power Tuning Tips**

**Before starting any installation steps:**

1. Never use Teflon tape on any system fittings. Tape debris will cause numerous problems ranging from clogged solenoids to blocked jets. Use the liquid thread sealer furnished with your NX system. A drop is all it takes.
2. Have your nitrous bottle filled by a reliable source, being sure it is filled to the correct capacity with **FILTERED** “NY-TROUS+” nitrous oxide.

## MOUNTING THE BOTTLE

The nitrous bottle should be mounted in the trunk area or outside of the passenger compartment. If this is not possible or practical a NHRA approved blow down tube and vent fitting (PN's 11708, 11709) must be installed. The positioning of the bottle should be as shown in illustration "A". This will allow the siphon tube to be covered at all times. The mounting brackets should be assembled on the bottle with the short bracket approx. 2" from the bottom. The long bracket should be place approx. 7" above the lower bracket on 10lb bottles. The upper bracket should be approximately 12" above the lower bracket on 15lb bottles. **Note: Before drilling holes to mount the bottle, be sure to check for clearance beneath the mounting surface i.e.: fuel tank, fuel lines, brake lines, etc.**

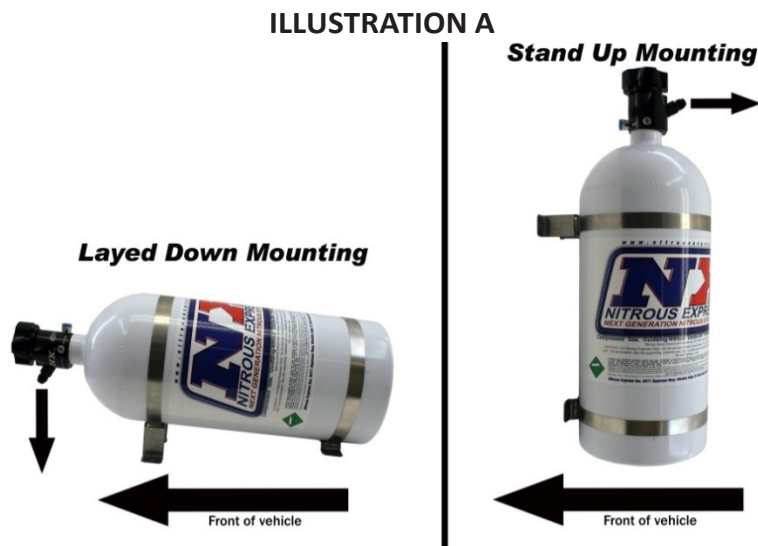

## ROUTING THE SUPPLY LINE

**NOTE: Place a piece of tape over the end of the hose to prevent debris from entering the feed line during the routing process.**

The 18-foot S.H.O. nitrous feed line may be routed to the engine compartment either through the passenger compartment or under the vehicle. Route the line carefully to prevent the possibility of restricting nitrous flow. If routed under vehicle, locate and drill a 3/4 inch diameter hole in a suitable area near the bottle valve for the main line. Starting at the bottle nipple (Do not attach line to the bottle nipple yet) route the line to the engine compartment. Following the factory fuel lines is usually the best path. Note: Keep maximum clearance between all moving parts, suspension components and hot engine components, securing the supply line where possible ("Zip Ties" are the best for securing the feed line). Be especially careful of the feed line being near any "HOT" electrical leads, one small spark will destroy the Teflon liner causing a nitrous leak.

**NOTE: The larger 4AN fitting connects to the nitrous bottle and the smaller (3AN) fittings connects to the nitrous plate. Make sure you DO NOT install backwards**

## MOUNTING THE NITROUS PLATE

Before any modifications are made under the hood, we suggest that you make a diagram of all hoses wiring and linkages.

1. Remove the throttle body from the intake manifold.
2. The nitrous plate should be installed as shown. (See Illustration B) Fuel and nitrous fittings are to the rear. Using supplied O-ring gasket reinstall the throttle body in front of the nitrous plate and torque to factory specs using the provided hardware
3. Select the horsepower setting that you want to start with, (please see jetting chart on the last page of these instructions) insert the proper nitrous jet in the fitting marked "N2O". Insert proper fuel jet in the fitting marked "Fuel" (CAUTION: You must always use a back-up wrench when tightening the

nitrous or fuel fittings, otherwise the jet fitting may break. Failure to use a back-up wrench will void the system warranty!!!!!!)

4. Connect the main feed line to the plate's nitrous fitting. The nitrous fitting can be identified by the "N2O" marked on the top of the plate. Connect the fuel supply line to the plate's fuel fitting; (the fuel fitting will be marked "FUEL"). NOTE: Always check each jet for obstructions before using.

### ILLUSTRATION B



### FUEL SUPPLY CONNECTION:

**WARNING: THE FUEL RAIL AND/OR FUEL LINES ARE UNDER HIGH PRESSURE. USE EXTREME CAUTION WHEN DISCONNECTING ANY FUEL LINE. QUICKLY COLLECT AND PROPERLY DISPOSE OF ANY EXCESS FUEL SPILLAGE.**

1. Install the supplied Fuel Rail Adapter on the driver's side fuel rail.
2. The Fuel Rail Adapter has 2-1/8npt holes. Install the 1/8NPT x 4AN Fitting in one, and the 1/8NPT hex plug in the other. NX Thread Sealer must be used on the pipe threads. DO NOT USE ON FLARE SIDE of fitting.
3. Install the desired jet in the fuel "IN" fitting on the plate. Connect the 3AN side of your S.H.O. fuel feedline to the plate's fuel "IN" fitting, connect the 4AN end of the hose to the 4AN fitting on your fuel rail adapter.

### ILLUSTRATION C

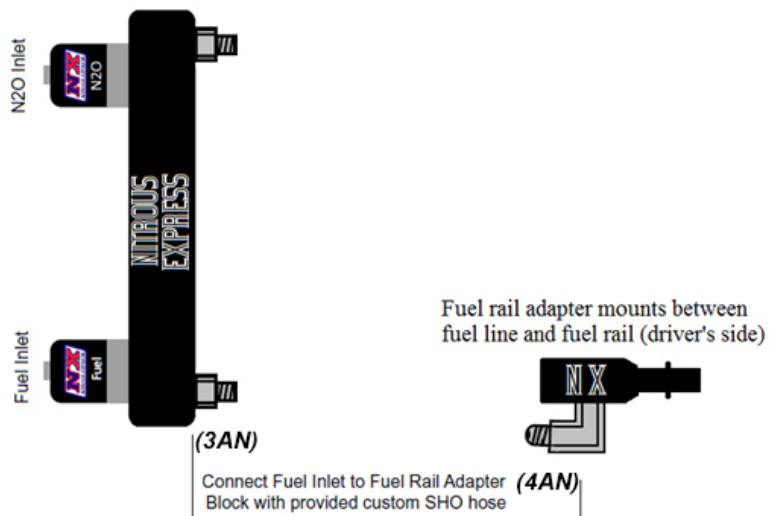

## ELECTRICAL HOOK-UP

Wiring diagram with optional electronic TPS WOT switch

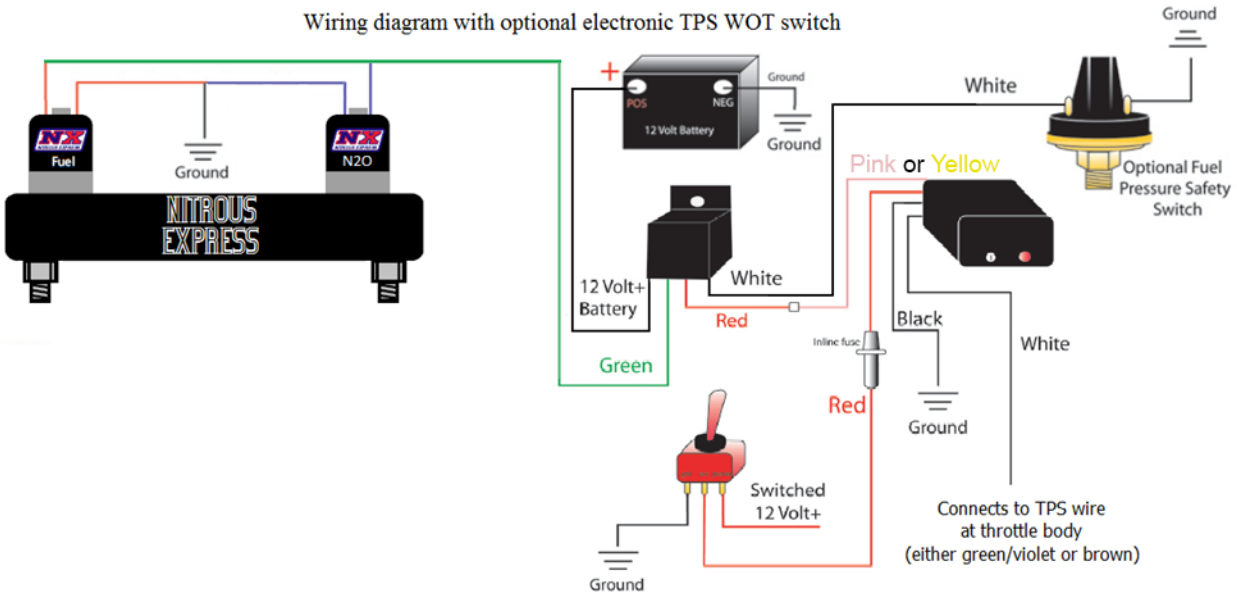

1. Mount the Master Arming Switch in a location that is within easy reach of and in plain sight of the driver.
2. Using 18-ga. wire and connectors supplied in the switch kit, connect a key switched HOT lead (12 VDC POSITIVE) to the "Power" terminal of the Master Arming Switch (this is the terminal on the opposite side of the gold terminal). (Use 5 amp inline fuse if desired). This power source must be controlled by the ignition switch.
3. Connect an 18-ga, grounded wire to the Ground terminal of the Master Arming Switch (this is the gold terminal on the master arming switch).
4. Connect an 18-ga. Grounded wire to the black wire of the TPS Wide Open Throttle Module.
5. Connect the white wire of the TPS Wide Open Throttle Module to the Yellow wire with a white stripe on the accelerator pedal.
6. Connect an 18-ga. wire from the center terminal "ACC" of the Master Arming Switch to the red wire of the TPS Wide Open Throttle Module
7. Connect the pink or yellow wire of the TPS Wide Open Throttle Module to the "Red" wire on the supplied heavy duty relay.(See wiring diagram).
8. Attach the white wire of the relay to ground. If using an optional fuel safety switch connect the switch between the white wire.
9. Using 12-ga. Wire, connect the "Black" wire of the heavy duty relay to the positive + post on the vehicle battery. (If desired a 40 amp fuse may be installed near the battery)
10. Using 12-ga. Wire, attach one wire from each of the solenoids to the "Green" wire on the relay. Note: These coils are direct current and it does not matter which wire is positive or negative. Now attach the two remaining solenoid wires to a good ground.
11. Reconnect the battery cable.

**Programming the TPS Wide Open Throttle Module. –Note these instructions are for TPS modules with only 2 LEDs on the module. If you have an older version with only 1 LED on the module please refer to [nitrousexpress.com/instructions.html](http://nitrousexpress.com/instructions.html) for programming instructions.**

The NX TPAS is designed to trigger a relay, 1 amp maximum current draw, at or near wide open throttle and automatically calibrates itself to work with rising or falling signal.

1. The NX TPS Wide Open Throttle Module may be installed inside or under the hood. Mount the unit in a place that it will be easy to access the learn button and view the LEDs. Make sure the unit is located away from any heat source, i.e. exhaust manifold, header, or EGR.
2. Following the wiring diagram, route all wires but make no connections.
3. You must determine which wire on your vehicle's TPS is the output signal to the vehicles computer. For Coyote mustangs, this is the brown wire at the throttle body.
4. Connect all wires per NX Self- Programming Throttle Position Activation Switch wiring diagram using a 1 to 3 amp fuse in series with the red wire.
5. On initial power up, press and hold the button while turning on switched +12 volts. The green LED should begin flashing indicating that the unit is not programmed.
6. Release the button.
7. With the throttle at pedal at idle position, press and hold the button until the red LED comes on (approximately 4 seconds). The green LED will continue to flash. Release the button and leave the throttle at Idle. The unit is now calibrating the idle position and making sure that the idle signal is stable. Wait for both LED's to turn off.
8. Now move throttle to wide open and hold for 1 second, then release back to idle (Red LED should come on to indicate that its working and waiting to check the calibration).
9. To check the calibration, move throttle to wide open again and then release to idle a second time. Once the check is complete, the Red LED will turn off and the Green LED will turn on indicating that the unit is calibrated and armed.
10. Once calibrated, the unit will activate the relay when the throttle opens to 90% or more and it will remain on as long as the throttle is between 90% and 100%. (When the relay is activated, both the red and green LEDs will be on). When the throttle closes to less than 90%, the unit will turn the relay and the red LED off. The green LED will remain on indicating that the unit is re-armed and ready for the next run.
11. If at any time during the calibration process the green and red LED's flash rapidly in an alternating pattern that means the calibration was not completed correctly. This can be the result of one of two things. Either the throttle was moved while it was calibrating the idle position or the TPS signal is not stable. Check wiring and recalibrate.

### **Testing the System**

1. Re-check all installation procedures to be sure nothing has been omitted.
2. Be sure the nitrous bottle has not been opened and the supply line is empty!
3. Using the toggle switch "ARM" the system.
4. Test solenoid operation by using the system activation switch. Both solenoids should "Click" (The nitrous solenoid should click loud, and the fuel solenoid will click soft). If they do not, re-verify all electrical connections and wiring diagrams.
5. Open the nitrous bottle and check all connections for leaks. With the lines disconnected from the solenoids, crack your nitrous bottle open to allow Nitrous pressure into the system. Check for any leaks that may be present, and tend to any that may exist. If the solenoid itself is not sealing, activate the nitrous solenoids a few times in rapid bursts to seat the plunger in the solenoids.
6. Do not start the engine if nitrous has been accidentally injected while the motor was not running! All nitrous must be cleared from the engine before starting; otherwise a violent intake manifold explosion could occur!
7. Start engine and check for any fuel leaks. Correct any leaks before proceeding.
8. The Nitrous System is now ready for normal usage.

9. All NX systems are intended for off road use only and should only be used in that context.

**Additional parts recommended for operating your nitrous system satisfactorily:**

- Nitrous Pressure gauge (PN 15508) - STRONGLY RECOMMENDED
- Purge Valve (PN 15605)
- Bottle Jacket (PN 15945 for 10lb bottle or PN 15946 for 15lb bottle)
- Fuel pressure Safety Switch (PN 15718)
- Bottle heater (NX 15940) - STRONGLY RECOMMENDED
- NHRA legal blow down vent fitting (PN 11709)
- NHRA legal blow down vent tube (PN 11708)
- TPS/RPM Window Switch (PN 18959)

**SAFETY TIPS**

Do not attempt to start engine if nitrous has been accidentally injected while the engine was not running. Disconnect coil wire and turn motor with throttle wide open for several revolutions before attempting to restart. If it is not possible to disable the ignition then the spark plugs must be removed and the engine cleared of all nitrous before attempting to start engine.

1. Never permit oil, grease, or any other readily combustible substances to come into contact with nitrous cylinders, valves, solenoids, hoses and fittings. Oil and certain gases (such as oxygen and nitrous oxide) may combine to produce a flammable condition.
2. Never interchange solenoids or other appliances used for one compressed gas with those used for another.
3. Identify the gas content by the label on the bottle before using. If the bottle is not identified to show the gas contained, return the bottle to the supplier.
4. Do not deface or remove any markings, which are used for content identification.
5. Cylinder valves should be closed except when nitrous is actually being used.
6. Notify supplier of any condition, which might have permitted any foreign matter to enter the valve or bottle.
7. Never drop or violently strike the bottle
8. Keep valves closed on all empty bottles to prevent accidental contamination.

**POWER TUNING TIPS:**

Nitrous oxide works well with all applications; 4 cycle, 2 cycle, diesel, and rotary engines. Each one has individual tuning characteristics, and these tips apply generally to each one. Nitrous oxide is referred to as “Liquid Supercharging” because it, in effect, does the same thing as a mechanical supercharger, adding more fuel and oxygen into each cylinder, thus producing more power. The biggest enemy of all supercharged, turbo charged and nitrous injected engines is “DETONATION”. The use of higher-octane fuel, and or a combination of better fuel and timing retard can control this. Remember detonation is a spark plug, head gasket and engine “KILLER”.

1. Your engine should be tuned to its maximum power prior to nitrous usage.
2. The ignition is an integral part of the nitrous system and must be able to ignite the mixture under very high cylinder pressures. The hotter the spark the better!
3. In stock engine applications and street usage the spark plugs should be at least 2 steps colder than stock. Do not use platinum tip, extended tip or any plug with multiple ground straps or split ground straps. When in doubt about heat range always go one step colder. A spark plug that is to “Hot” will cause detonation, burned plugs, poor performance, and engine damage. In competition engines always use the coldest plug available. Never use an extended tip plug in a racing engine.



4. The NX nitrous system is so advanced, (technology, engineering, and workmanship) that huge amounts of timing retard is not required. We recommend 2 degrees timing retard for each 50 horsepower boost as a starting point. Your engine may need more or less depending on your combination.
5. Your fuel system is also an integral part of the nitrous system, be sure it is in top shape and all filters are clean.
6. Engine operating temperature should be between 160 and 200 degrees prior to nitrous usage.
7. Never "lug" your engine and hit the nitrous system, use the system at wide-open throttle only, nitrous should not be used below 3000 rpm's. If you do any of the above a serious "Back Fire" could result in engine damage.
8. The better the exhaust system the better the nitrous system will work.
9. Do not attempt to drill or alter the jets, solenoids, or the tubes in the nitrous plate. These items are engineered to their maximum capability. Any modification you can make will decrease power and destroy engine parts.
10. Do not mix or attempt to match any other brand solenoids, plate, or nozzles with this system. Any attempt at this could lead to serious engine damage.
11. All of our systems are designed to operate at 1000 PSI bottle pressure. This is extremely important and cannot be stressed enough. If your bottle pressure is below 1000 PSI the system will run rich and will not produce the advertised horsepower. If the bottle pressure is above 1000 PSI the system will run lean, possibly damaging engine parts. This pressure is easily monitored by using a NX liquid filled pressure gauge (PN 15509). Note: When the ambient temperature is below 97 degrees a bottle warmer is required (PN 15940 or 15941). An NX bottle jacket (PN15945 or 15946) will help stabilize bottle pressure in the winter and summer.

**CAUTION: NEVER USE AN OPEN FLAME TO HEAT A NITROUS BOTTLE. THIS IS A VERY DANGEROUS AND POTENTIALLY FATAL PRACTICE!!!!!!!!!!!!!!**

12. A purge valve (PN 15605) is recommended on all NX systems. When the weather begins to get hot a purge valve is worth up to a tenth of a second on a 1/4 mile pass. Note: The correct purging procedure for drag racing is: 1. Complete the burnout. 2. Light the pre-stage bulb. 3. Push the purge button three times, one second each. 4. Stage immediately, GO FAST.
13. If there is a question about the purity of your nitrous supply, a filter (PN15610 or 15607) should be used when refilling your bottle. Just attach the filter to your bottle when you take it to be refilled. Contaminated nitrous will cause serious damage to the nitrous solenoids and possibly to your engine. This is a lifetime renewable filter.
14. If you have questions about the suitability of your torque converter or gear ratios, call the factory tech line for the inside scoop.
15. Your nitrous bottle should be turned off when not in use (even between runs). An NX remote bottle opener (PN 11107) will make this task much easier.
16. Start with the lowest power setting in your system. Don't try to be the track "Hero" on your first pass. Remember start out small and work your way up, NX systems produce more real horsepower than any other brand on the market today.
17. If the solenoids must be disassembled for cleaning or rebuilding always use the proper wrench (PN 15921). Do not use any clamping device on the solenoid tower, instant non-warranty, damage will result.
18. If you run an NX system of 150+ horsepower you must use a high octane racing type fuel. These are some tips to help you choose and maintain the correct fuel for your application:
  - A. The most important statistic you should look for in the fuel specifications is the "MON" or motor octane number. In most cases the higher the number the more timing you can run and detonation will not be a problem
  - B. Most V-8 or V-12 engines with stock compression will run on "93" unleaded pump gas with up to 150 horsepower boost, most 4 or 6 cylinders with stock compression can use up to 75 horsepower.

- C. Racing engines with high compression or higher must run racing fuel. The higher the compression, and the higher the boost, the higher the “MON” must be.
  - D. With nitrous usage usually the highest “MON” available is the one that should be used.
  - E. All NX systems are calibrated to use fuel with .730 specific gravity or “SG”. If you use a fuel with a lower “SG” you must use a larger fuel jet to compensate for the lighter fuel. If you use a fuel with a higher “SG”, a smaller fuel jet will be required. Most unleaded pump gas is .730 SG or above.
  - F. Racing fuel should be stored in an airtight, dark container. Exposure to atmosphere allows very important elements to evaporate, lowering the octane of the fuel. Sunlight oxidizes the lead contained in racing fuel, since this is the most important ingredient used to raise octane it must be protected.
  - G. Never leave the fuel in your car between race days. This allows evaporation of the very important “High end” hydrocarbons and lowers the octane of the fuel.
  - H. Never buy racing fuel from an underground or vented storage tank. Always demand to see where and how the fuel is stored; a sealed drum is the only correct way.
  - I. AV gas or aviation fuel is not compatible with nitrous usage, don’t be tempted by the cheap price, instant engine damage will result!
  - J. For a fuel recommendation, contact your NX dealer.
19. All vehicles, including full competition race cars, must have an alternator to provide adequate amperage required by today’s racing accessories. Add up all the amps required by your car, you’ll be surprised!
20. If you have trouble with your NX system or any related parts, call your dealer first. If you still need help call the factory tech line 940-767-7694 9:00AM-5:00PM CST Mon-Fri. We are the nitrous experts and will give straight answers to your questions.

In conclusion.....

This instruction sheet and power tuning tips are valid only for a NX system. If you have a kit from another manufacturer this information will not help you! A tune up from any other brand of nitrous kit will not work with the NX “Next Generation” technology.

**DO NOT LISTEN TO:**

- A. YOUR BUDDY!
- B. YOUR BUDDY’S FRIEND!
- C. THE LOCAL NITROUS GURU!
- D. ANY ARTICLE IN ANY MAGAZINE

If you follow the foregoing suggestions, your NX system will operate trouble free and provide years of thrills.

**ABOVE ALL REMEMBER TO RACE SAFE AND HAVE FUN!**



## Ford Coyote EFI Plate Jetting w/integrated Solenoids

Select the desired horsepower level and fuel type to determine the nitrous and fuel jet requirements.

Ignition timing should be retarded 1.5 - 2 degrees per 50 hp of nitrous being sprayed.

Spark plugs should be copper core, 2 steps colder than stock, gapped no larger than .035.

**CHECK ALL JETS FOR OBSTRUCTIONS UPON INSTALLATION!!!!!!!**

Coyote Plate @55psi Fuel Pressure			
HP	N2O	Gasoline	E85
50	35	20	23
75	41	23	27
100	52	28	32
125	57	29	34
150	62	32	38
200	136	36	43

With Integrated Solenoids on Plate

**This jetting chart is for informational purposes only, NX is not responsible for misuse or misapplication!**