



MAXIMIZER
PROGRESSIVE CONTROLLER **6**

Installation Instructions

Read all Instructions before beginning!!!!

Caution – EXTREME DANGER – Caution

Do not use or mix any other manufacturer's products with any Nitrous Express products.

Do not use or mix any Nitrous Express products with any other manufacturer's products.

THESE INSTRUCTIONS APPLY TO NITROUS EXPRESS PRODUCTS ONLY!

FOR SANCTIONED RACE USE ONLY - NOT FOR SALE OR USE IN CALIFORNIA

1. Overview

The Maximizer 6 progressive controller operates up to four separate stages of nitrous or water methanol based on either time, RPM, MPH, throttle percentage or boost pressure. Whether your engine is naturally aspirated or forced induction, gasoline or diesel, the Maximizer 6 is the first choice. The Maximizer 6 has multiple progression options to cover a variety of racing types. These progression options are described below:

Time based progression. This option is a popular choice for drag racing applications where you always start from a dead stop. This option is very easy to fine tune so that you leave soft enough to eliminate wheel spin. As you go down track, the controller smoothly adds more nitrous as traction increases.

RPM based progression. This option works well for vehicles that have enough traction to handle full nitrous power at the top of first gear but want to limit power at lower engine RPMs. This mode allows you to add a little nitrous in the lower engine RPMs and ramp into full nitrous as the engine rpm increases.

Speed based progression. This option is great for racers who sometimes begin racing from a dead stop and other times begin racing from a rolling start. The nitrous controller will automatically limit nitrous to a smaller shot at low speeds where traction is limited while providing a larger shot at higher speeds where traction is more plentiful.

Throttle percentage progression. This option allows you to “pedal” the car in the event of wheel spin. Nitrous flow smoothly increases and decreases as you “work” the throttle, allowing you to regain traction and continue racing. This is very beneficial to road race and drifting vehicles. The throttle percentage feature is also beneficial for street cars because it allows you to introduce a small amount of nitrous at mid throttle while smoothly transitioning to full nitrous power as you press the throttle to the floor. The feeling is like driving a car with twice the cubic inches.

Pressure (Boost) based progression. This is a useful option for use on turbocharged diesels and gasoline applications. Boost progression allows nitrous to come on strong to eliminate that dreaded turbo lag but then ramps out the nitrous smoothly to let the mighty turbo do its thing. The end result is monster power with zero lag, even with a HUGE turbo. On diesel applications it will not allow nitrous delivery until the engine starts to see boost, preventing a nitrous engine stall.

AFR (Air Fuel Ratio) compensation and protection. The maximizer 6 monitors the engines Air Fuel Ratio (from optional wide band O2 module), and automatically adjusts the fuel and nitrous solenoid output to achieve the desired Air Fuel Ratio (target AFR is user adjustable). As bottle pressure drops toward the end of a run, the maximizer 6 will automatically adjust the solenoid output so you maintain a consistent and safe AFR. Air Fuel Ratio safety cut off limit (too rich and too lean) are user adjustable so the controller will completely shut off nitrous flow if the Air Fuel Ratio goes outside the user defined limits.

2. Max 6 hardware installation

The Max 6 is designed to be installed almost anywhere on the vehicle. Select a location that is away from heat sources that can damage the wires. Mounting in a dry location is also recommended so the USB connections to not corrode.

Output 1 and output 2 N2O Solenoid outputs (12 Gauge red and Blue wires. Blue 1st stage, Red 2nd stage)

The Max 6 controls the nitrous and fuel solenoids by varying the pulse width to the ground wires of the

solenoids. Before wiring the Max 6 you must decide if you want to use AFR Control or not (the solenoid wiring is different for each configuration).

If using AFR Control, connect the ground wires of the nitrous solenoid(s) to the 12awg blue wire of the Max 6. Connect the ground wire(s) of the fuel solenoids to the 12awg red wire(s) of the Max 6. When in ARF Control mode, the nitrous controller will use Output 1 and Output 2 to control a single stage of nitrous. When using this wiring strategy it is imperative that you select "AFR Control" in the Max 6 software under Tuning/Configuration, Input Config, Setup, Controller.

If you do not plan to use AFR Control, you should connect the ground wires of the nitrous and fuel solenoids for stage one to the 12awg blue wire of the Max 6. If using stage 2, connect the ground wires of the nitrous and fuel solenoids for stage 2 to the 12awg red wire of the Max 6. When using this wiring strategy it is imperative that you select either "2-Outputs 60 Amp" or "1-Output 120 Amp" in the Max 6 software under Tuning/Configuration, Input Config, Setup, Controller.

Output 3 (White/Blue Stripe 20awg) – Stage 3 ground side driver, requires external high current driver.

Output 4 (White/Red Stripe 20awg) – Stage 4 or Water/Meth ground side driver, requires external high current driver.

Controller Ground (dual black 12awg) should be connected to chassis ground as close as possible to the battery. You should also install a 8 gauge ground cable from the negative battery terminal to the chassis to eliminate ground loop issues with external sensors etc.

Power Input (red 20awg) should be connected to the nitrous arming switch and fused for 5 amps

RPM Input (grey 20awg) is designed to work with most Tachometer signals (down to 3 Volts), without the need for a separate adapter. It can be connected to a tach signal, 12 volt coil trigger signal, or fuel injector signal. DO NOT connect it to the coil if the vehicle has a Capacitive Discharge ignition box (MSD, Mallory etc.).

Throttle Input (blue 20awg) is designed to work with most throttle-position-sensors (TPS) and wide open throttle (WOT) switches. Connect it directly to the signal wire from your TPS. For use with a WOT switch we recommend connecting the blue wire of the Max 6 to one terminal of the WOT switch and connecting the other terminal of the WOT switch to the positive 12v output of your master arming switch. **NOTE: This is a required input, the controller will not function without this wire connected to either a TPS wire or a WOT Microswitch!!**

VSS (Vehicle Speed Sensor) Input (white 20awg) is designed to read most factory VSS signals as well as pulses from a magnetic driveshaft sensor or a magnetic speedometer cable sensor.

Input #2 (Tan 20awg) This input is most commonly used to deactivate nitrous when the transbrake is active. Requires a 12-volt positive signal to activate it (see Input #2 in the software section). Alternatively, Input #2 can be used to activate or deactivate any stage of nitrous. See the text above wiring diagrams for more details.

N2O pressure (Violet 20awg) This input is compatible with the optional NX nitrous pressure sensor (part # 15533)

Bottle heater output (White/Black Stripe 20awg) provides a ground output to activate a bottle heater relay.

MAP (Manifold Absolute Pressure) Used for Boost or Pan Vacuum. (yellow 20awg) Connect this wire to your MAP sensor signal.

Sensor + 5v (orange 20awg) this wire is used to power any 5 volt sensors that are not already powered by an ECU.

Sensor Ground (black 18awg) this wire is used to ground any 5 volt sensors that are not already grounded by an ECU.

Input A, B and C are universal 0-5 volt user defined inputs and can be configured multiple ways depending on the user's desires.

Input A (Violet/White Stripe)

Input B (Violet/Pink Stripe)

Input C (Violet/Yellow Stripe)

4-pin Deutsch connector. Mates to optional touch screen display.

Display Power (Red)

Display GND (Black)

Display TxD (Brown/Yellow Stripe)

Display RxD (Brown/White Stripe)

Timing Outputs:

Stage 1 Low-side(Ground) timing output (Gray/Red 20awg) provides an output signal to trigger the timing retard function of an ignition box or an external timing retard device. This output will provide ground.

Stage 1 High-side(12v+) timing output (Yellow/Red 20awg) provides an output signal to trigger the timing retard function of an ignition box or an external timing retard device. This output will provide 12-volt positive.

Stage 2 Low-side(Ground) timing output (Gray/Blue 20awg) provides an output signal to trigger the timing retard function of an ignition box or an external timing retard device. This output will provide ground.

Stage 2 High-side(12v+) timing output (Yellow/Blue 20awg) provides an output signal to trigger the timing retard function of an ignition box or an external timing retard device. This output will provide 12-volt positive.

Single Stage 60 AMP wiring WITHOUT AFR CORRECTION:

Input Config. Setup, output #1 and #2 should be set to "2 output 60AMP".

First stage ground (blue) should be connected to the nitrous and fuel solenoids. (60 AMP Max)

Second stage ground (red) is not used. (can be used later for a second stage.) (60 AMP Max)

If not using a transbrake Input #2 should be set to 'do nothing to this output'.

If using a transbrake, Input #2 should be set to 'disarm this output'.

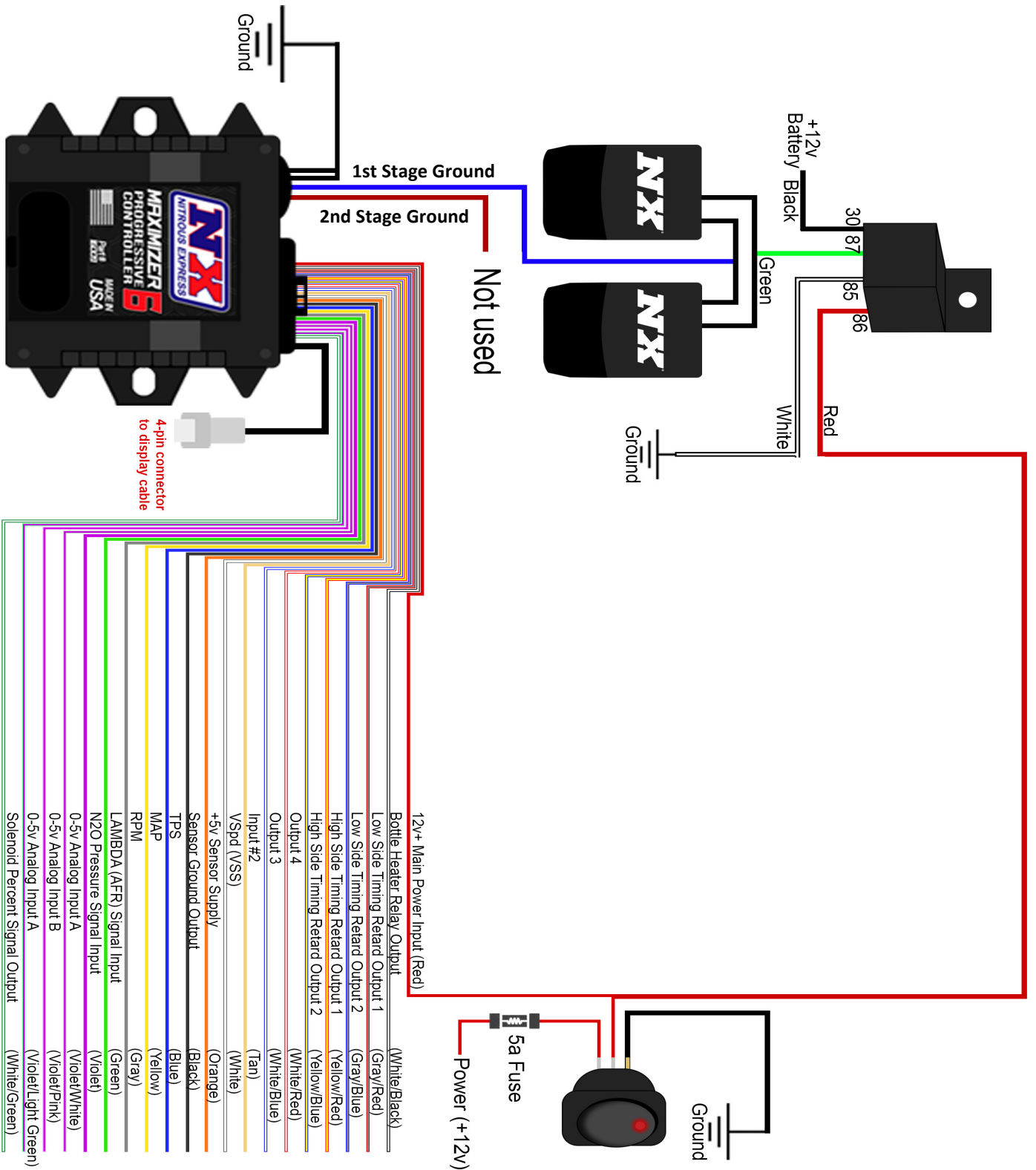

Single Stage 120 AMP wiring WITHOUT AFR CORRECTION:

Input Config. Setup, output #1 and #2 should be set to 1 output 120AMP.
 First stage ground (blue) second stage ground (red) should be tied together.
 If not using a transbrake Input #2 should be set to 'do nothing to this output'.
 If using a transbrake, Input #2 settings should be set to 'disarm this output'.

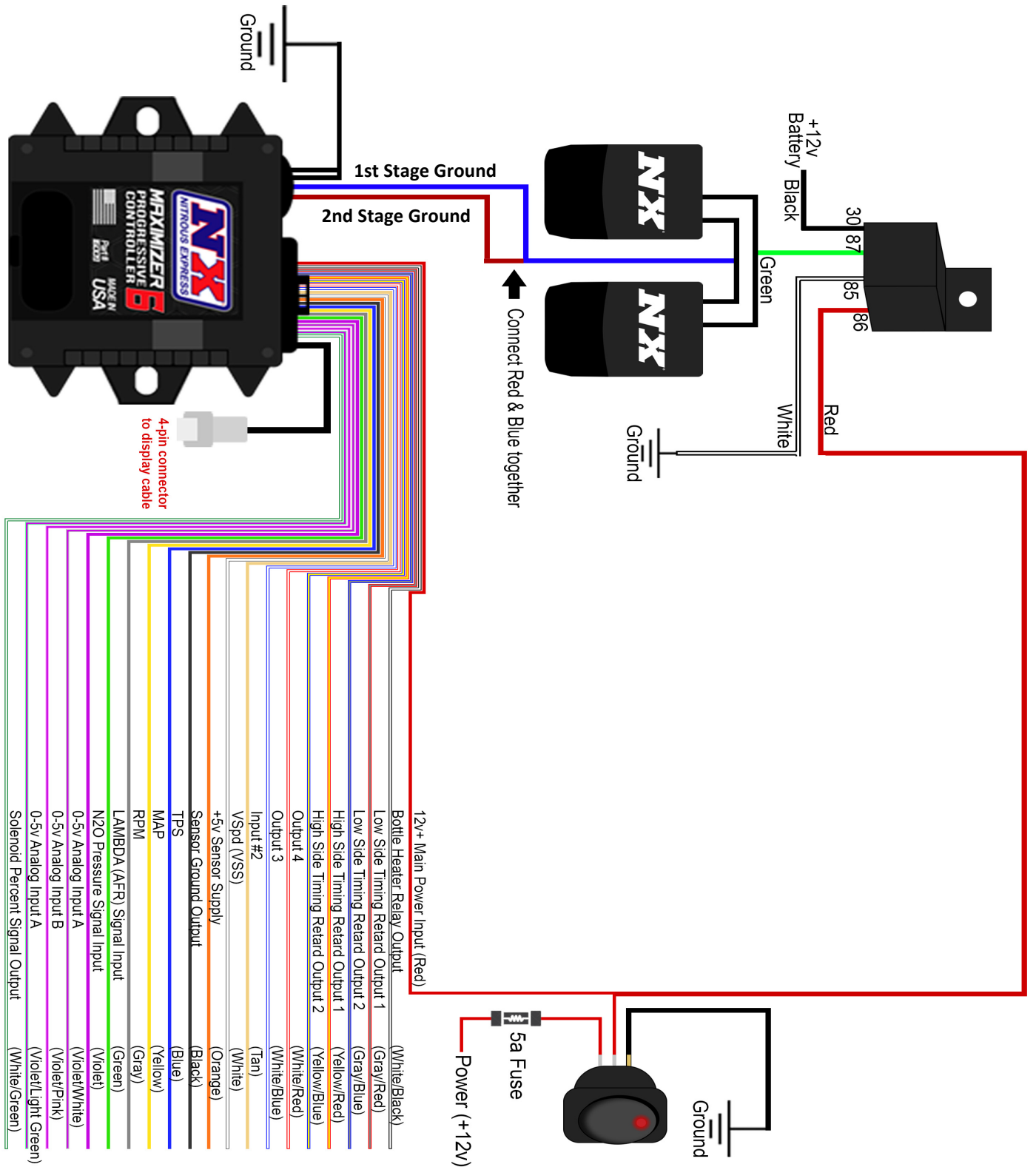

Dual Stage wiring WITHOUT AFR CORRECTION:

Input Config. Setup, output #1 and #2 should be set to "2 outputs 60AMP".
 If not using a transbrake Input #2 should be set to 'do nothing to this output'.
 If using a transbrake, Input #2 should be set to 'disarm this output'.

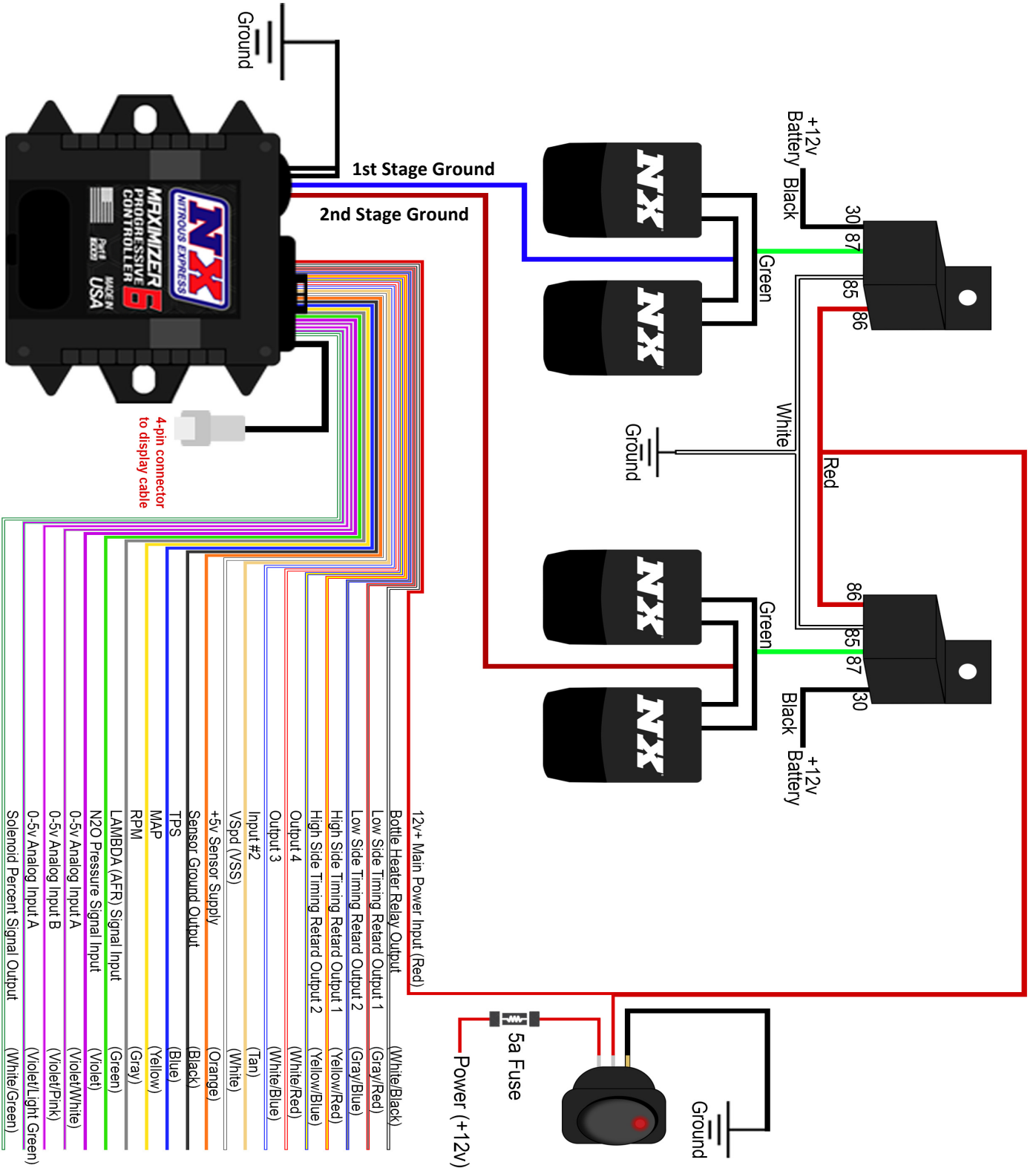

Single Stage Wiring WITH AFR Control:

Input Config. Setup, output #1 and #2 should be set to "AFR control".
 If not using a transbrake Input #2 should be set to 'do nothing to this output'.
 If using a transbrake, Input #2 should be set to 'disarm this output'.

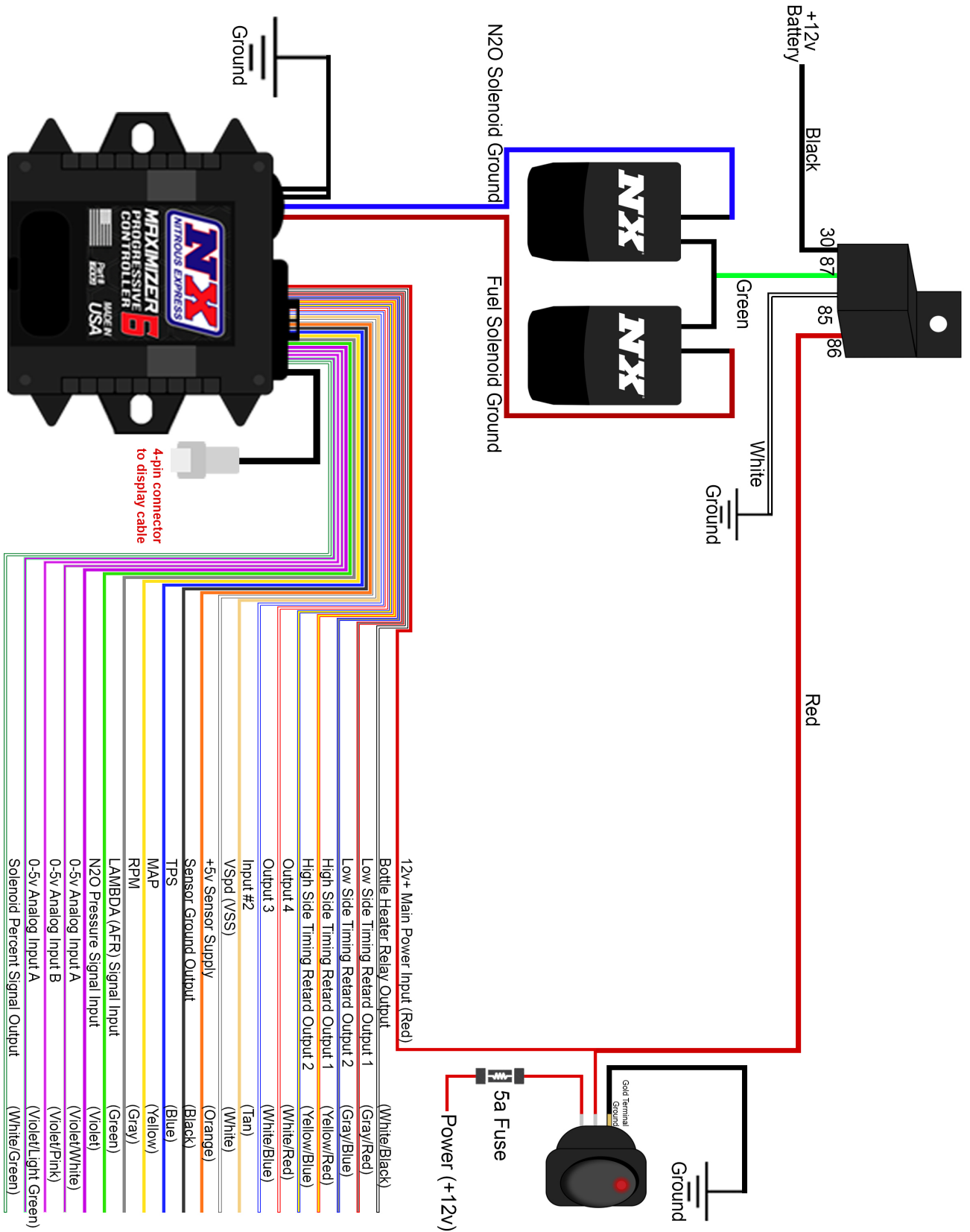

Dual-Stage wiring with trans-brake and 2nd stage on button

This wiring configuration changes the way "Input #2" is used. Instead of using Input #2 to activate the internal trans brake, we are using input #2 to activate the second stage. We're adding a relay to provide the transbrake function by deactivating the TPS wire while the transbrake button is pressed. With this wiring configuration the Input #2 settings should be as follows:

Output 1 setup screen for input #2 should be set to 'do nothing to this output'. Output 2 setup screen for input #2 should be set to 'arm this output'.

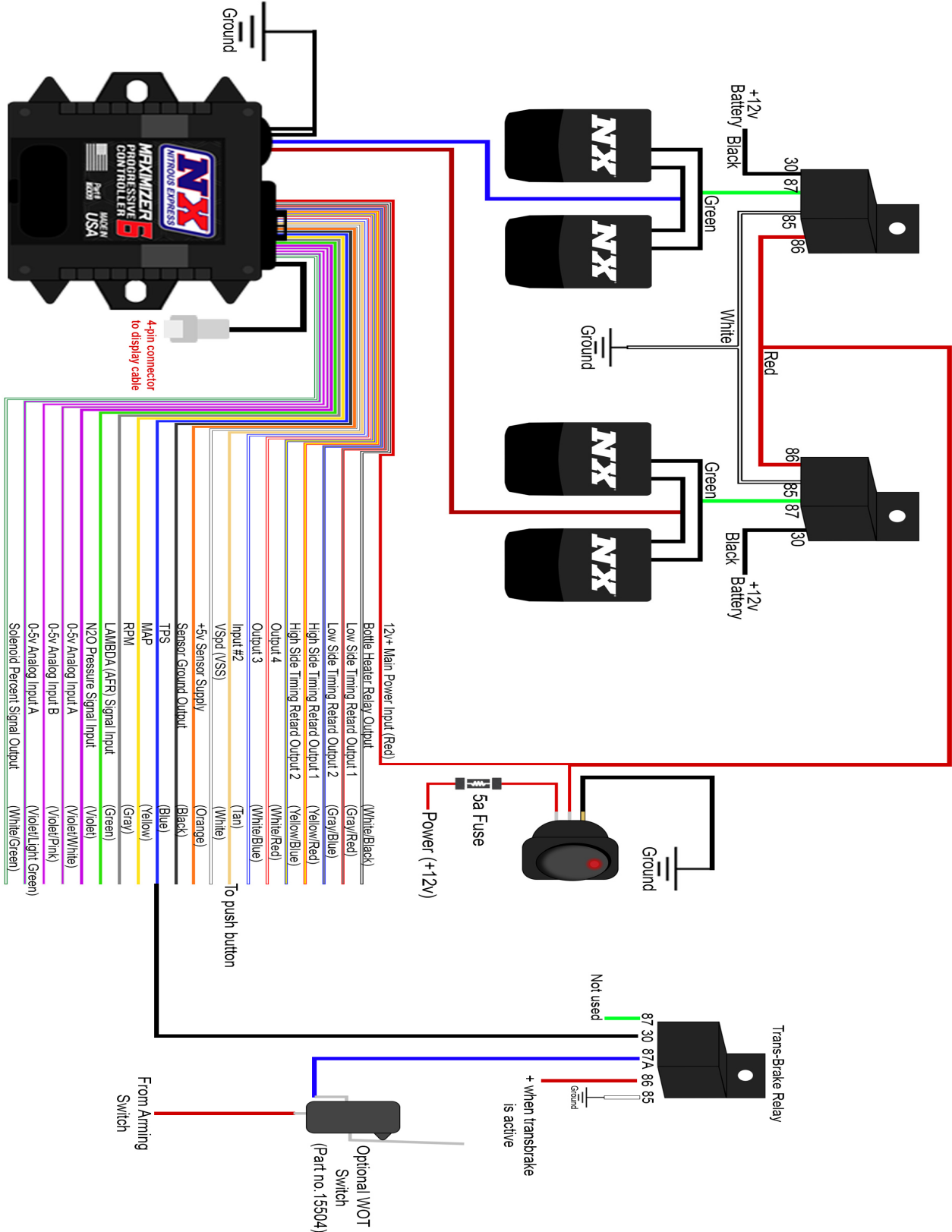

3. PC Software Installation

DO NOT connect the controller to your PC until you have installed the software.

You will need to have your PC connected to the internet for the software installation and the installation of the maximizer 6 drivers. You will need to go to www.nitrousexpress.com/downloads.html to download the latest version of the maximizer 6 software. Once the file is downloaded you will need to "Unzip" the file.

Locate the compressed folder (NXMax6setup.zip) that you want to extract files or folders from.

Do one of the following:

To extract a single file or folder, double-click the compressed folder to open it. Then, drag the file or folder from the compressed folder to a new location.

To extract the entire contents of the compressed folder, right-click the folder, click Extract All and select a file location that will be familiar to you.

Once the files are extracted from the .zip file, open setup.exe and follow on screen prompts.

ATTENTION: THE Max 6 must be powered up and the computer must be connected to the internet before the USB cable is plugged into the laptop for the first time!! Otherwise the wrong drivers will be assigned to the hardware!!

3.1 Entering User Data. When you change settings the changes are implemented immediately. After you make changes, we recommend that you save a configuration file to your computer by selecting FILE / SAVE or by pressing the SAVE icon in the software.

3.2 Tuning Configuration

If using the AFR Control configuration, connect the ground wires of the nitrous solenoid(s) to the 12awg blue wire of the Max 6. Connect the ground wire(s) of the fuel solenoids to the 12awg red wire(s) of the Max 6. When in ARF Correction Closed Loop mode, the nitrous controller will use stage one and stage two outputs to control one stage of nitrous. When using this wiring strategy it is imperative that you select "AFR Control" in the Max 6 software under Tuning/Configuration, Input Config, Setup, Controller.

If you do not plan to use the AFR Control, you should connect the ground wires of the nitrous and fuel solenoids for stage 1 to the 12awg blue wire of the Max 6. If using stage 2, connect the ground wires of the nitrous and fuel solenoids for stage 2 to the 12awg red wire of the Max 6. When using this wiring strategy it is imperative that you select either "2-Outputs 60 Amp" or "1-Output 120 Amp" in the Max 6 software under Tuning/Configuration, Input Config, Setup, Controller.

Outputs 1, 2 and 3 control nitrous solenoids.

Output 4 controls either a 4th stage of nitrous or a water methanol pump.

Heater control allows automatic control of a bottle heater. Enter the desired bottle pressure and the heater output will turn on below the desired pressure setting and will turn off above the desired pressure setpoint.

Wheelie control reduces solenoid output percent based on the graph settings. A separate angle module is required.

3.3 RPM

Selecting the enable box within the RPM window turns on the RPM window switch function of the maximizer 6. NO check mark removes all RPM related configuration options and tells the controller to ignore RPM. RPM Multiplier selects the correct pulse count for the RPM counter. Use the following as a guide to determine the correct setting:

a) Using a trigger signal from a PCM - TACH signals will typically have 1 pulse per cylinder during 2 revolutions of the crankshaft (1 full cycle) and therefore the correct setting would be \div (½ the number of cylinders)

Example: When using a TACH signal

4 cylinder setting would be \div 2

6 cylinder setting would be \div 3

8 cylinder setting would be \div 4

Note: for LS1 tach signals set the multiplier to \div 2

b) Using a trigger signal from a coil - first determine how often it fires per revolution of the crankshaft. The correct setting would be:

x1 for a waste-spark since it fires each revolution of the crankshaft

x2 for a full-sequential since it fires every other revolution.

This setting must be verified prior to operation. Verifying this setting will require the unit to be

installed on the vehicle with the engine running. Make sure the rpm display on the software matches your vehicles tach at idle as well as at mid to high engine RPMs.

RPM Cutoff allows you to set the upper RPM threshold above which the nitrous will be turned off. If you remove the check mark the nitrous will not turn off at the cutoff.

RPM Trigger allows you to set the minimum RPM required before the Nitrous can be triggered.

3.4 Wideband Set-up

When using a wide band o2 sensor you will need to enter the calibration data from your wide band manufacturer into the Max 6 input config screen.

3.5 AFR Control

When closed loop control is active, the Max 6 will reduce pulse width of either the nitrous or fuel solenoids to achieve your target AFR set point. We recommend initially tuning the nitrous system with closed loop control disabled. Once you have verified that the nitrous system is achieving a reasonable AFR with closed loop control disabled, you can enable the closed loop control starting

on sensitivity level 1. If the air fuel ratio never reaches the target set point or is slow to meet the AFR set point you may increase the sensitivity to a higher level. If you go too high on the sensitivity level the AFR

will overcorrect and will end up oscillating rich, lean, rich, lean and so on. The goal is

to run the lowest sensitivity level possible that will still reach the target AFR.

Although the max 6 will pull fuel or nitrous to achieve the target AFR, you will feel a reduction in power when nitrous is pulled to compensate for a lean condition. For this reason, we recommend jetting your nitrous system a little rich so the controller will pull fuel instead of nitrous to achieve the target AFR.

Important!!!! When in ARF Correction Closed Loop mode, the nitrous controller will only control one stage of nitrous with the internal drivers. Furthermore, when the AFR Correction Closed Loop stage is selected in the software, stage 1 and stage 2 may not be selected. Note: If using the AFR Control, connect the ground wires of the nitrous solenoid(s) to the 12awg blue wire of the Max 6. Connect the ground wire(s) of the fuel solenoids to the 12awg red wire(s) of the Max 6.

3.6 Ramp Set-up

The software allows you to drag and drop any dot on the ramp between 0-100%. The controller will extrapolate between the dots thus creating a nitrous curve instead of the traditional ramp. We have provided some additional tools to help smooth the overall curve, which we discuss in the following sections.

Reset to Straight Line allows you to set the curve to a straight line between the Start and Final targets.

Smooth Points will apply a smoothing algorithm to your curve. This button can be pressed multiple times until the desired curve is achieved

Undo is an undo button. If you applied the smooth points feature or dragged a dot, this feature will undo the change. It has multiple levels so you can undo several changes

3.7 Upload / Download Configuration

DO NOT connect the controller to your PC until you have installed the software.

Before programming the maximizer 6, it must first be installed in your vehicle because it requires

12-volt power. To connect the maximizer 6 to your PC, use the USB cable supplied in the box. Plug the USB cable into the maximizer 6 and into an available port on your PC. Clicking on the "Find The Controller" button will connect the PC software to the maximizer 6. Now you can either manually enter the configuration settings that you want in the Max 6 or you can upload a previously saved Configuration file from your PC into the Max 6. Once you have entered or uploaded the desired settings the changes will be effective immediately. Clicking File, then Save (or the Save button) will save a configuration file on your PC.

4. Final Testing

1) Disconnect the solenoids from the Max 6 to prevent them from firing. On a new install we recommend that you connect a temporary light in place of the solenoids and make a test run to verify that the solenoids will be active only when desired.

2) Turn on the ignition power and start the engine.

3) Verify that the engine rpm displayed in the Max 6 software matches your tachometer

4) Verify that the TPS percentage reads 0% with the accelerator pedal in the idle position and 100% with the accelerator pedal in the Wide Open Throttle position.

- 5) If using the VSS input, drive the vehicle and verify that the speed displayed matches the vehicle speedometer.
- 6) If using the MAP input, drive the vehicle and verify that the MAP displayed matches the vehicles boost gauge.
- 7) If using the Lambda / ARF input, drive the vehicle and verify that the Lambda / AFR displayed matches your wide bands display and that the AFR displayed seems reasonable for whatever condition the engine is currently running.
- 8) Arm the Max 6 and verify that the LED on the Max 6 is illuminated when armed.
- 9) Once proper operation is confirmed, you can remove the temporary light, reconnect the solenoids and go have fun.

5. Software and Firmware Updates

Free updates are available for the Max 6 and related software at www.nitrousexpress.com

6. Limited Warranty

Nitrous Express (the warrantor) hereby warrants its product to the original purchaser thereof (the consumer) against any and all defects in workmanship and material under the following terms and conditions: The Limited Warranty is specifically limited to the original purchaser of the products and is enforceable only by such original purchaser. In the event of a defect in workmanship or material of the products, the Warrantor will repair or replace the product, or any defective part or parts thereof, at the election of the Warrantor, without charge to the consumer for such repair or replacement. This Limited Warranty shall not apply to labor charges, freight, material or other incidental expenses in connection with removal and/or replacement of such defective product on the consumer's vehicle. This Limited Warranty shall extend for a period of ninety (90) days, commencing from the date of the original purchase by the Consumer. The only exception to this limited term is for the NX "Lightning" series solenoids, which have a limited lifetime warranty (does not include electrical components, labor, or freight). The maximum liability of Nitrous Express in connection with this warranty shall not under any circumstances exceed the contract price of the product claimed to be defective.

Printing Errors

Every effort has been made to proof all copy prior to printing. However, we do not accept responsibility for typographical errors either in prices or content.

Rights Reserved

As our technology expands, we may find it necessary from time to time to make changes in some of the items offered in our catalog. Nitrous Express reserves the right to make, without notice, changes in design, material and specifications or to make product changes without liability.

7. Technical Assistance

Trained experienced technicians are available to provide any information you may need between the hours of 9:00 a.m. to 4:00 p.m. CST. Call (940) 767-7694 for technical assistance.